

My CrossWave® Cordless Max is leaking | Support

Note: If there is too much water on floor, go over area without pressing trigger to suction up excess water

- Remove clean water tank from back of machine
 - Check for cracks, leaks or deformation on tank
 - If tank is damaged, a new tank should be ordered
- With clean tank still removed, check for cracks/leaks on black cap and damage on rubber gasket
 - If there are cracks or damage, a new cap should be ordered
- Fill clean tank with water, securely install cap onto tank, firmly push back onto machine, leaving no gaps between tank and body of machine
- Remove and empty the dirty water tank
 - Inspect tank for cracks and leaks
 - If there are cracks or damage, a new dirty tank assembly needs to be ordered
- Put dirty tank back onto machine, until it clicks into place
- Remove brush window by pulling tab upward
 - Rinse to remove build-up & debris
 - Examine for cracks, if a crack is found, a new brush window needs to be ordered
 - Reattach brush roll window by lining up tabs on front edges of foot
 - Rotate window down into place until it clicks

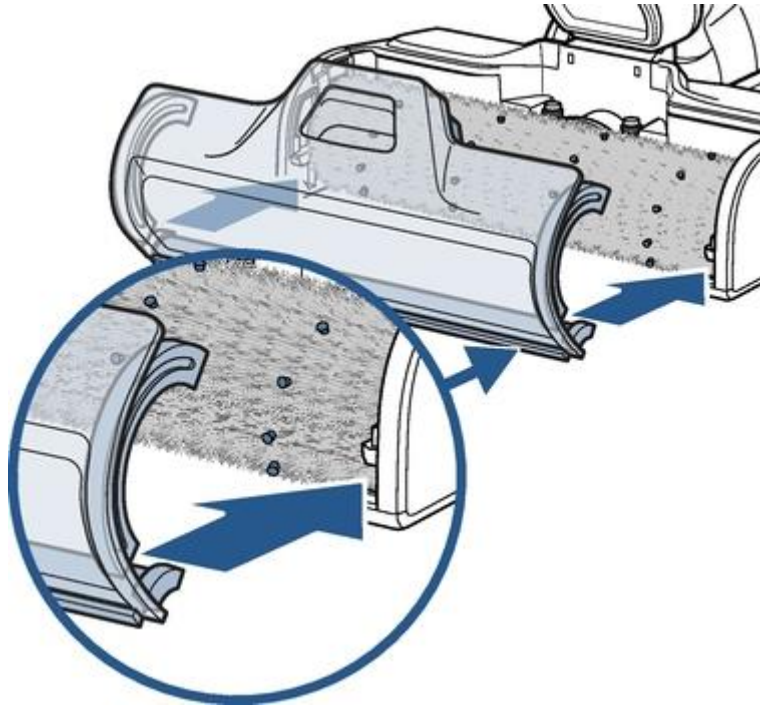

- Turn machine on
- Hold spray trigger for 10-15 seconds and test for leaks

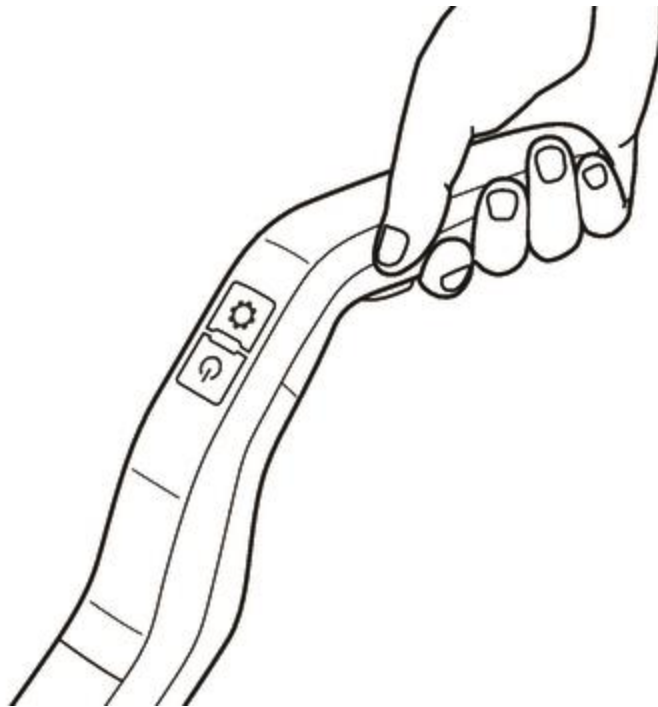

If machine is leaking from side vents:

- There may be too much foam building up within - be sure to use recommended amount of formula as indicated on clean tank
- Also be sure to use proper **BISSELL CrossWave** formula
- Dirty water level may have surpassed full line and float indicator did not activate - empty and see if this resolves issue