



SPINWAVE® R5 ROBOTIC VACUUM MODEL 3475F

What's in the Box?	4	Mop Mode	8
Docking and Charging Your Robot.....	4	Cleaning the Brush Roll	10
Connecting to the App.....	5	Replacing the Edge Cleaning Brush.....	11
Before You Clean	5	Cleaning the Sensors.....	11
Mapping.....	6	Storing Your Robot.....	11
Scheduled Cleaning.....	6	Troubleshooting.....	11
Dry Vacuum Mode.....	6	Limited Warranty.....	12



Product Overview

- 1. Tank Release Button
- 2. Power Switch
- 3. Mop Pads
- 4. Bumper
- 5. Play/Pause Button
- 6. Home Button

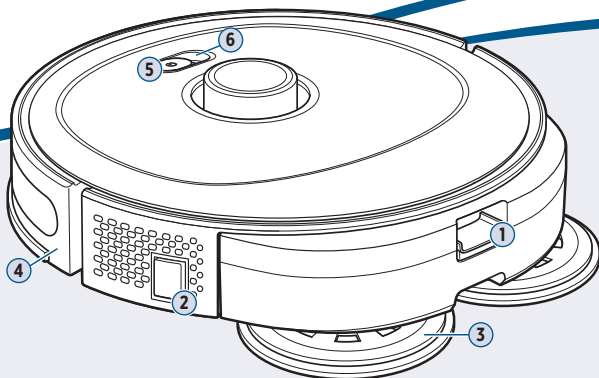

SYMBOL	EXPLANATION
	Caution.
	Read operator's manual.
	Risk of fire.
	Risk of electric shock.
	Do not expose to rain.
	Store indoors.
	Do not overwet carpet. Use only on carpet moistened by the cleaning process.

SYMBOL	EXPLANATION
	Disconnect power before servicing.
	Do not freeze.
	Lock.
	Protection against moving parts.
	Risk of automatic start-up.
	Use warm water, temperature up to 60°C.

SYMBOL	EXPLANATION
	Use only BISSELL® cleaning formulas intended for use with this machine.
	Check the manufacturer's tag before cleaning textile. "W" on the tag as shown means you can use your cleaner.
	This symbol on the product and/or accompanying documents means that used electrical and electronic products should not be mixed with general household waste. For proper treatment, recovery and recycling, please take this product to designated collection points. Please contact your local authority for further details of your nearest designated collection point.

IMPORTANT SAFETY INSTRUCTIONS



READ ALL INSTRUCTIONS BEFORE USING YOUR APPLIANCE.

When using an electrical appliance, basic precautions should be observed, including the following:



WARNING

TO REDUCE THE RISK OF FIRE, ELECTRIC SHOCK OR INJURY:

- This appliance can be used by children aged from 8 years and above and persons with reduced physical, sensory or mental capabilities or lack of experience and knowledge if they have been given supervision or instruction concerning use of the appliance in a safe way and understand the hazards involved. Cleaning and user maintenance shall not be made by children without supervision.
- Children should be supervised to ensure that they do not play with the appliance.
- Keep hair, loose clothing, fingers, and all parts of body away from openings and moving parts of the appliance and its accessories.
- This appliance is not intended for use by persons (including children) with reduced physical, sensory or mental capabilities, or lack of experience and knowledge, unless they have been given supervision or instruction concerning use of the appliance by a person responsible for their safety.
- If the charger supply cable is damaged, it must be replaced by the manufacturer, its service agent or similarly qualified person in order to avoid a hazard.
- Do not incinerate the appliance even if it is severely damaged. The batteries can explode in a fire.
- Do not use non-rechargeable batteries.
- The battery is to be disposed of safely.
- Under abusive conditions, liquid may be ejected from the battery; avoid contact. If contact accidentally occurs, flush with water. If liquid contacts eyes, additionally seek medical help. Liquid ejected from the battery may cause irritation or burns.
- Recharge only with the charger specified by the manufacturer. A charger that is suitable for one type of battery pack may create a risk of fire when used with another battery pack.
- The battery must be removed from the appliance before it is scrapped.
- Unplug charger from electrical socket when not in use, before cleaning, maintaining or servicing the appliance, and if your appliance has an accessory tool with a moving brush, before connecting or disconnecting the tool.
- This appliance must only be supplied at safety extra low voltage corresponding to the marking on the appliance.
- The appliance is only to be used with the power supply unit provided with the appliance.
- WARNING: For the purposes of recharging the battery, only use the detachable supply unit provided with this appliance.
- This product contains a wireless device. Refer to website for regulatory information.
- Turn OFF all controls before unplugging. Do not pull or carry charger by cable, use cable as a handle, close door on cable, or pull cable around sharp edges or corners.
- Keep charger cable away from heated surfaces.
- To unplug, grasp the charger plug, not the cable.
- Do not handle charger plug or appliance with wet hands.
- Do not charge the unit outdoors.
- The appliance must be disconnected from the supply mains when removing the battery.
- Do not recharge, disassemble, heat above 60°C, or incinerate.
- Never put batteries in mouth. If swallowed, contact your physician or local poison control.
- Prevent unintentional starting. Ensure the switch is in the OFF-position before picking up or carrying the appliance. Carrying the appliance with your finger on the switch or energising appliance that has the switch on invites accidents.
- Do not use appliance that is damaged or modified. Damaged or modified batteries may exhibit unpredictable behavior resulting in fire, explosion or risk of injury.

- Do not expose appliance to fire or excessive temperature. Exposure to fire or temperature above 130°C may cause explosion.
- Follow all charging instructions and do not charge the appliance outside of the temperature range specified in the instructions. Charging improperly or at temperatures outside of the specified range may damage the battery and increase the risk of fire.
- Have servicing performed by a qualified repair person using only identical replacement parts. This will ensure that the safety of the product is maintained.
- Do not modify or attempt to repair the appliance except as indicated in the instructions for use and care.
- Keep the temperature range of between 4-40°C when charging battery, storing unit or during use.
- Use appliances only with specifically designated battery packs. Use of any other battery packs may create a risk of injury and fire.
- For use only with charger model E-Tek ZD012M190060AU.
- For use only with BISSELL® Docking Station model 1630160.
- When battery pack is not in use, keep it away from other metal objects, like paper clips, coins, keys, nails, screws or other small metal objects, that can make a connection from one terminal to another. Shorting the battery terminals together may cause burns or a fire.
- Place the cables from other appliances out of the area to be cleaned.
- Do not operate the vacuum in a room where an infant or child is sleeping.
- Do not operate the vacuum in an area where there are lit candles or fragile objects on the floor to be cleaned.
- Do not operate the vacuum in a room that has lit candles on furniture that the vacuum may accidentally hit or bump into.
- Do not allow children to sit on the vacuum.
- Do not position Docking Station near stairs or cliff edges.
- Plastic film can be dangerous. To avoid danger of suffocation, keep away from children.
- Use only as described in this user guide. Use only manufacturer's recommended attachments.
- Do not put any object into openings. Do not use with any opening blocked; keep free of dust, lint, hair, and anything that may reduce air flow.
- Do not use to pick up flammable or combustible liquids, such as petroleum, or use in areas where they may be present.
- Do not pick up toxic material (chlorine bleach, ammonia, drain cleaner, etc.).
- Do not use appliance in an enclosed space filled with vapours given off by oil-based paint, paint thinner, some moth-proofing substances, flammable dust, or other explosive or toxic vapours.
- Do not pick up hard or sharp objects such as glass, nails, screws, coins, etc.
- Do not pick up anything that is burning or smoking, such as cigarettes, matches or hot ashes.
- Do not use without filters in place.
- Do not use outdoors or on wet surfaces.
- Do not use with damaged cable or charger. If appliance is not working as it should, has been dropped, damaged, left outdoors, or dropped into water, return it to a service center.
- Battery pack and charger base output terminals are not to be short-circuited.
- Clear the area to be cleaned. Remove excess clutter like power cords and small objects from the floor that could entangle the appliance and tidy up the cleaning area. Lift items such as curtains and tablecloths off the floor.
- CAUTION: Only allow children at least 8 years old to use the battery charger. Give sufficient instruction so that the child is able to use the battery charger in a safe way and explain that it is not a toy and must not be played with. Instruct the child not to try and recharge non-rechargeable batteries because of the danger of eruption.
- This appliance contains lithium ion type batteries that are non-replaceable.
- Examine the battery charger regularly for damage, especially the cord, plug and enclosure. If the battery charger is damaged, it must not be used until it has been repaired.
- Do not turn your appliance ON until you are familiar with all instructions and operating procedures.

Wet Mop Mode for Hard Surfaces

- Do not immerse. Use only on surfaces moistened by the cleaning process. Use only BISSELL cleaning products intended for use with this machine.
- Use only the type and amount of liquids specified under the operations section of this guide.

Dry Vacuum Mode

- Do not use the vacuum on a wet surface.

SAVE THESE INSTRUCTIONS ORIGINAL INSTRUCTIONS. FOR OPERATION ON A 220-240 VOLT A.C. 50-60 HZ POWER SUPPLY ONLY.







THIS MODEL IS FOR HOUSEHOLD USE ONLY.

IMPORTANT INFORMATION

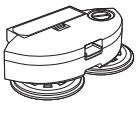
- The software included in this product contains open source software. The open source licenses associated with this product may be obtained by visiting www.BISSELL.com/opensource.
- A limited exchange of personal information is required to utilize all features of the robot.

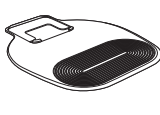
What's in the Box?

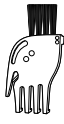
Standard accessories may vary by model.

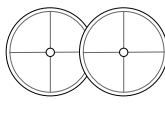
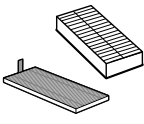
				
BISSELL® SpinWave® Robot with Dry Tank	Mop Tank with Mop Pads	Docking Station	Docking Tray	Power Adapter
				
Cleaning Tool (comes attached to dry tank)	Trial Formula	Replacement Edge Cleaning Brush (select models)	Extra Mop Pads	Extra Filters

Docking and Charging Your Robot

▶ Open up the **BISSELL Connect App** for how-to videos.

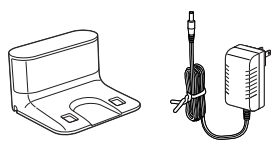
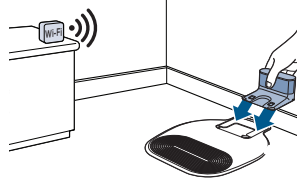
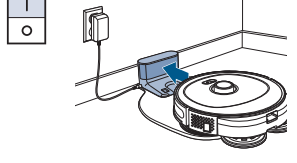

Note: The docking station and docking tray must be installed on a hard surface. The robot's soft surface sensors prevent it from cleaning carpets and area rugs in mop mode. Be sure the device is near your WiFi router and the robot is fully charged or in the dock during the pairing process.

		
1. Remove bottom cover of charging base and plug in power adapter. Excess cord can be wrapped inside dock for easy storage. Replace cover and plug into wall outlet.	2. Place back of docking tray firmly against a wall and make sure there are no obstructions around it. Tip the docking station into the docking tray.	3. Turn the robot ON and place on the docking station. The first charge will take 5-6 hours.

Connecting to the App

Download the BISSELL Connect App to customize your clean. Create cleaning zones or keep out zones, schedule cleanings, view the robot's cleaning path, track the cleaning history, view notifications, troubleshoot and more – all from the palm of your hand.

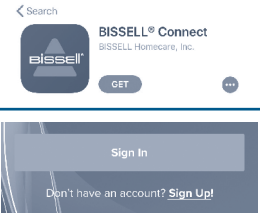
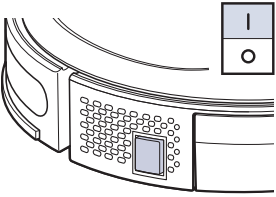
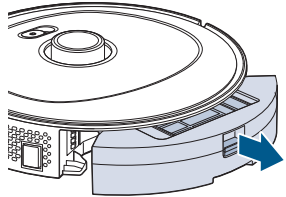
 <p>Search</p> <p>BISSELL® Connect BISSELL HomeCare, Inc.</p> <p>GET</p> <p>Sign In</p> <p>Don't have an account? Sign Up!</p>		
<p>1. Download BISSELL Connect App from App Store or Google Play.</p> <p>Once downloaded, open app and sign in or create a new login.</p>	<p>2. Make sure you're near your WiFi router before turning robot ON (I).</p> <p>From the app, select "Have a BISSELL Connected Product? Connect it now." Choose "SpinWave R5" from the menu.</p>	<p>3. Remove dirt bin and turn robot over to access the setup QR code.</p>

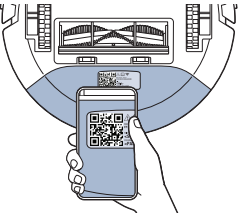
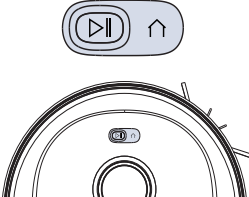
	
<p>4. Scan QR code and follow instructions in app to pair.</p>	<p>5. To pair your robot, press and hold play + home buttons for 3 seconds.</p>

Before You Clean

- Pick up loose toys, cords, clothing, or other objects that may interfere with your robot.
- Secure or move fragile items as your robot may push lighter objects across the floor.

Mapping

Your robot will create a virtual map of your home to allow customized cleaning options. Open the BISSELL Connect App and press start. The robot will begin mapping and cleaning at the same time. Your robot will clean a room in sections starting with the perimeter of that section and filling in with a structured pattern.

Note: If the robot is moved to an area outside of the originally mapped area, it will see this as a new space and restart the mapping process. This will delete the original map and any zones previously created.

Tips for Mapping

- Perform mapping in dry vacuum mode to ensure the robot maps all floor types.
- Open doors and remove barriers to allow the robot to map freely.
- After mapping, use the app to customize your clean. Create virtual “go” or “no-go” zones, and create virtual walls on the map.

Scheduled Cleaning

 Download the **BISSELL Connect App** to set up automatic features.

You can designate a day and time for your robot to run automatically using the BISSELL Connect App. Once the robot is connected to the app and a map has been created of your home, go to the Schedule tab and follow the on-screen prompts.

Dry Vacuum Mode

Manual Cleaning

In dry vacuum mode, your robot uses a combination of a dual length edge cleaning brush, a rotating brush roll and powerful suction to clean multiple floor types including hard floors and carpet.

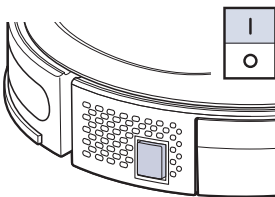
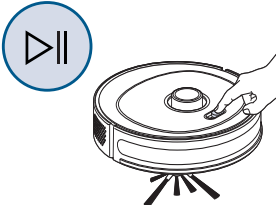
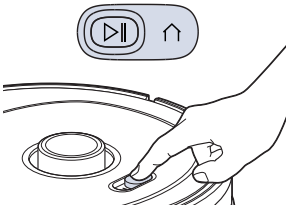
		
<p>1. Turn robot ON (I).</p>	<p>2. Start robot automatically with app, or manually by pressing play/pause button.</p>	<p>3. When robot is finished cleaning, it will automatically return to dock. If you want it to return to dock before cleaning is complete, press play/pause button, then press home button.</p>

Spot Mode

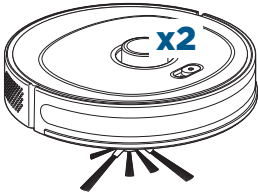
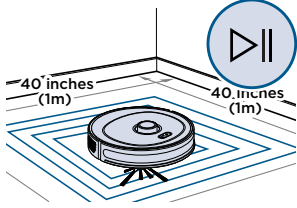
	
<p>1. Place robot in center of area you want to clean.</p> <p>To start cleaning, press play/pause button twice or select "Spot" mode in the BISSELL Connect App.</p>	<p>2. Robot will clean in a square pattern covering an area approximately 40" x 40" for about 5 minutes. It will beep when finished and return to dock after spot clean is complete.</p>

Maintaining the Dirt Bin

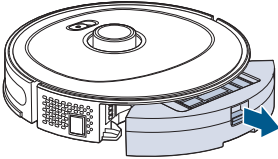
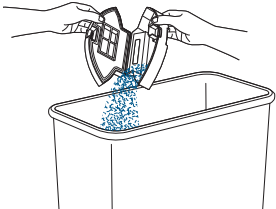
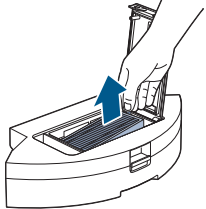
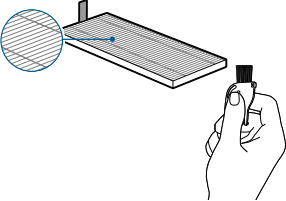
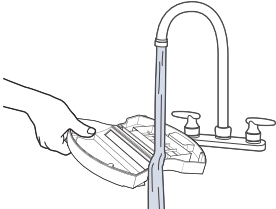
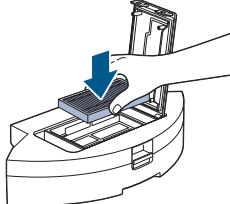
		
<p>1. Turn power switch OFF. Press button on top of dirt bin and pull to remove.</p>	<p>2. Open dirt bin by pulling both sides apart. Empty debris into a trash can.</p>	<p>3. Lift top cover of dirt bin and pull out filter.</p>
		
<p>4. Use cleaning tool to brush the filter. Do not wash.</p>	<p>5. With filter removed, rinse dirt bin with tap water. Ensure dirt bin is completely dry before reinstalling. Do not machine wash dirt bin.</p>	<p>6. Once clean, reinstall filter, close top cover and push dirt bin back into the machine.</p>

Mop Mode

▶ Open up the **BISSELL Connect App** for how-to videos.



In mopping mode, your robot will vacuum and mop at the same time. It uses dual rear rotating mop pads combined with a BISSELL® formula to clean your home's hard floors while automatically avoiding soft surfaces like area rugs and carpet.

Filling Your Mop Tank

<p>1. Choose your formula*.</p>	<p>2. Turn power switch OFF. Press button on top of tank and pull to remove.</p>	<p>3. Twist to unlock tank cap and pull up to remove.</p>

<p>4. Add water to "WATER" fill line first.</p>	<p>5. Add BISSELL formula to "FORMULA" fill line second.</p>	<p>6. Twist cap back into place.</p>

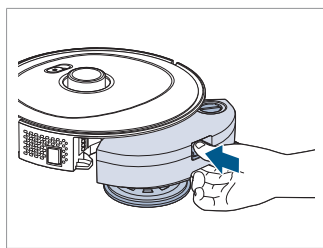

7. Reinstall tank and make sure it clicks into place.

Note: Hold tank level to avoid leaking.

*Compatible BISSELL formulas include: Multi-Surface, Natural Pet, Hard Floor Sanitize, Wood Floor
*Kills 99.9% of Enterobacter aerogenes (ATCC 13408) and Staphylococcus aureus (ATCC 6538)

⚠ WARNING To reduce the risk of fire, use only BISSELL® cleaning formula for full size machines in your carpet washer. Use of cleaning formulas that contain eucalyptus, lemon or pine oil may damage this appliance and void the guarantee. Chemical spot cleaners or solvent-based soil removers should not be used. These products may react with the plastic materials used in your carpet washer causing cracking or pitting.

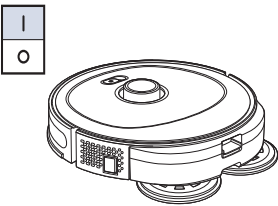
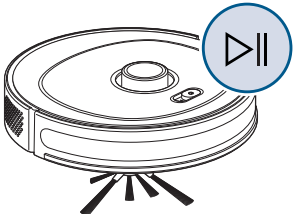
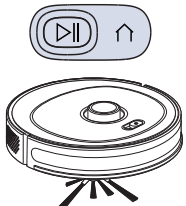

Manual Cleaning

		
<p>1. Turn robot ON.</p>	<p>2. Start robot automatically with app, or manually by pressing play/pause button.</p>	<p>3. When robot is finished cleaning, it will return to dock. If you want it to return to dock before cleaning is complete, press play/pause button, then press home.</p>

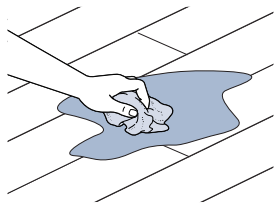

Sanitising with Spot Mode

In Spot Mode, use BISSELL® Hard Floor Sanitize Formula to sanitise floors after tough messes like pet accidents, or give areas extra attention with BISSELL® Multi-Surface or Natural Pet Formulas.

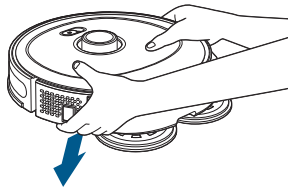
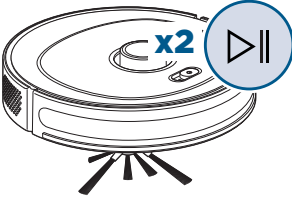
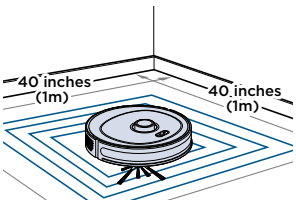
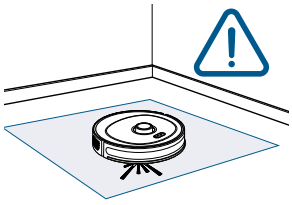
Note: You can sanitise three to four different areas around your home with a single tank.

		
<p>1. Wipe up mess with a disposable towel.</p>	<p>2. Add BISSELL Hard Floor Sanitize formula following steps on page 8.</p>	<p>3. Place robot in center of the area you want to clean.</p>
		
<p>4. To start cleaning, press play/pause button twice or select "Spot" mode in the BISSELL Connect App.</p>	<p>5. Robot will clean in a square pattern covering an area approximately 40" x 40" for about 5 minutes. It will beep when finished and return to dock.</p>	<p>6. Use caution when walking through area as floor may be slippery. Allow to remain wet for 5 minutes.</p>

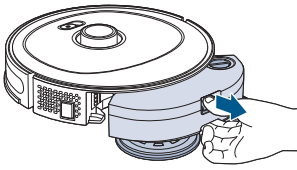
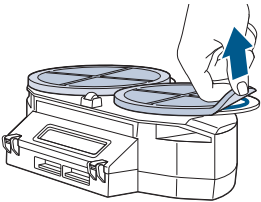
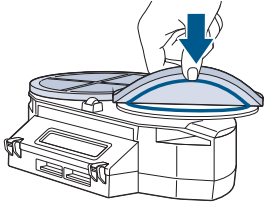
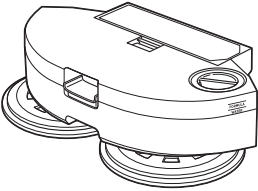
Maintaining the Mop Pads and Debris Trap

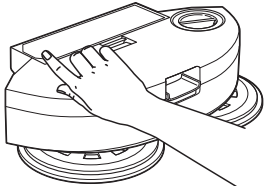
		
<p>1. Turn power switch OFF. Press button on top of mop tank and pull to remove. Place tank upside down on a soft surface.</p>	<p>2. Firmly pull up on mop pads to remove from mop pad drivers. Replace mop pads if damaged. Machine wash separately in warm water.</p>	<p>3. To reattach, use middle hole on pads to align with driver.</p>
		
<p>4. Empty dirt bin after each use, including after mopping.</p>	<p>5. Push tab on the top of mop tank to open dirt bin and empty it.</p>	<p>6. Lift up on filter cover located on top of tank and remove filter. Brush off dust and debris from filter.</p>

Cleaning the Brush Roll

↖ Check out the **BISSELL Connect App** for tips and videos on maintenance.

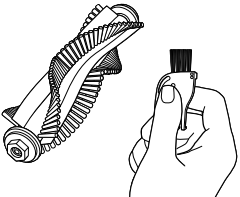
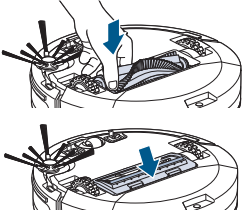
		
<p>1. Turn power switch OFF. Pinch tabs on brush guard inward and pull to remove. Lift to remove brush roll.</p>	<p>2. Clean brush roll with cleaning tool. Remove endcaps from brush roll by pulling apart to thoroughly clean.</p>	<p>3. Reinstall brush roll and brush guard.</p>

⚠ WARNING To reduce the risk of fire, turn the power switch OFF before performing maintenance or troubleshooting checks.

Replacing the Edge Cleaning Brush

The edge cleaning brush needs to be occasionally cleaned to work more effectively.

		
1. Pull up on base of brush.	2. Once removed, rinse or soak edge cleaning brush in water. Be sure it is completely dry before reinstalling.	3. Push brush directly onto holder until it clicks into place.

Cleaning the Sensors

After repeated use, debris can accumulate on the sensors of the robot and impact its performance.

Turn the power switch OFF and wipe the sensors with a cloth to remove any debris.

Sensors and Contacts

1. Cliff Sensors
2. Charging Contact Points
3. Soft Surface Avoidance Sensor

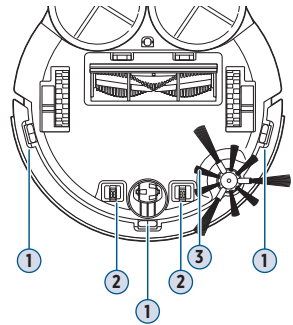

Storing Your Robot

Store your robotic vacuum cleaner safely indoors where it is unlikely to be damaged. Store with clean, dry mop pads. Any solution remaining in the mop tank should be emptied prior to storage.

Troubleshooting

For a comprehensive walkthrough of your product and support tips and videos, visit support.BISSELL.com.

⚠ WARNING To reduce the risk of fire, turn the power switch OFF before performing maintenance or troubleshooting checks.

NOTICE

- To reduce the risk of a leaking condition, do not store machine where freezing may occur. Damage to internal components may result.
- Disconnecting the battery will destroy the appliance and invalidate the warranty.

Limited Warranty

This limited warranty is provided by BISSELL® International Trading Company B.V. ("BISSELL") and applies in Australia and New Zealand. It gives you specific rights. It is offered as an additional benefit to your rights under law. You also have other rights under The Australian Consumer Law or New Zealand Consumer Laws, whichever applies to you. You can find out about your legal rights and remedies by contacting your local consumer advice service. Nothing in this warranty will replace or lessen any of your legal rights or remedies. If you need additional instruction regarding this warranty or have questions regarding what it may cover, please contact BISSELL Consumer Care or contact your local distributor.

This warranty is given to the current owner of the product with the original sales receipt. The original sales receipt must include the product(s) purchased, the date purchased, and which country it was purchased from new. You must be able to evidence the date of purchase and show the product was purchased in Australia or New Zealand to submit a claim under this warranty. You will receive the warranty that is applicable to the country where your product was originally purchased, as shown on the original sales receipt. If you use the product outside of the country where it was purchased, your warranty may be void in BISSELL's sole discretion. It may be necessary to obtain some of your personal information, such as a mailing address, to fulfill the terms of this warranty. Any personal data will be handled pursuant to BISSELL's Privacy Policy, which can be found at global.BISSELL.com/privacy-policy.

Limited One-Year Warranty

For one year from the date of purchase by the original purchaser, subject to the *EXCEPTIONS AND EXCLUSIONS identified below, BISSELL will repair or replace (with new, refurbished, lightly used, or remanufactured components or products), at BISSELL's option, free of charge, any defective or malfunctioning part or product.

BISSELL recommends that the original packaging and original proof of purchase with the date of purchase and country where purchased be kept for the duration of the warranty period in case you want to redeem the warranty during the warranty period. Keeping the original packaging will assist with any necessary re-packaging and transportation but is not a condition of the warranty.

If your product is replaced by BISSELL under this warranty, then the new item will benefit from the remainder of the term of this warranty (calculated from the date of the original purchase). The period of this warranty shall not be extended whether or not your product is repaired or replaced.

*Conditions of Warranty

This warranty applies to products used for personal domestic use and not commercial or hire purposes. Consumable components and attachments such as filters, belts, shells, water tanks, scraping strips, brushes, and mop pads, which must be replaced or serviced by the user from time to time, are not covered by this warranty.

This warranty does not apply to any defect arising from fair wear and tear, including but not limited to the battery discharging time shortening due to the aging or use. Damage or malfunction caused by the user or any third party whether as a result of accident, negligence, abuse, neglect, or any other use not in accordance with the user guide is not covered by this warranty. An unauthorised repair (or attempted repair) may void this warranty whether or not damage has been caused by that

repair/attempt. Removing or tampering with the Product Rating Label on the product or rendering it illegible will void this warranty.

Except as set out below, BISSELL and its distributors are not liable for any loss or damage that is not foreseeable or for incidental or consequential damages of any nature associated with the use of this product including without limitation loss of profit, loss of business, business interruption, loss of opportunity, distress, inconvenience, or disappointment. Except as set out below, BISSELL's liability will not exceed the purchase price of the product.

BISSELL does not exclude or limit in any way its liability for (a) death or personal injury caused by our negligence or the negligence of our employees, agents or subcontractors; (b) fraud or fraudulent misrepresentation; (c) or for any other matter which cannot be excluded or limited under law.

To make a claim under this warranty contact BISSELL Australia PTY LTD (details below). Contact BISSELL prior to returning any goods. Where agreed, BISSELL will reimburse reasonable postage / handling costs (if any) for returning goods to BISSELL. To claim expenses incurred in making a claim under this warranty please provide BISSELL with a copy of the receipt of the expenses by email or post.

For Australian Consumers Only: Our goods come with guarantees that cannot be excluded under the Australian Consumer Law. You are entitled to a replacement or refund for a major failure and compensation for any other reasonably foreseeable loss or damage. You are also entitled to have the goods repaired or replaced if the goods fail to be of acceptable quality and the failure does not amount to a major failure.

Important Notes

Please keep your original sales receipt. It provides proof of the date of purchase and where it was purchased in the event of a warranty claim. See warranty for details.

Please note that using your BISSELL machine outside of its country of original purchase and/or use with a power converter may damage your BISSELL machine and damage caused by mismatched power voltage will not be covered by your warranty.

Please note that putting vinegar, bleach, dish soap, detergent, homemade soap, and other non-BISSELL products in your BISSELL machine may damage your BISSELL machine. Damage caused by using non-BISSELL products in your machine will not be covered by your warranty.

Consumer Care

If your BISSELL product should require service or to claim under our limited guarantee, please contact us.

Australia

Telephone: 1300 247 735
Website: BISSELL.com.au
Address: 789 Springvale Road, Mulgrave, Victoria 3170
Email: consumercareau@bissell.com

New Zealand

Telephone: 0800 247 735
Website: www.BISSELL.co.nz
Address: 789 Springvale Road, Mulgrave, Victoria 3170
Email: consumercarenz@bissell.com

NOTICE Disconnecting the battery will destroy the appliance and invalidate the warranty.

