



# CLEANVIEW™ HYDROSTEAM™

UPRIGHT CARPET CLEANER WITH STEAM





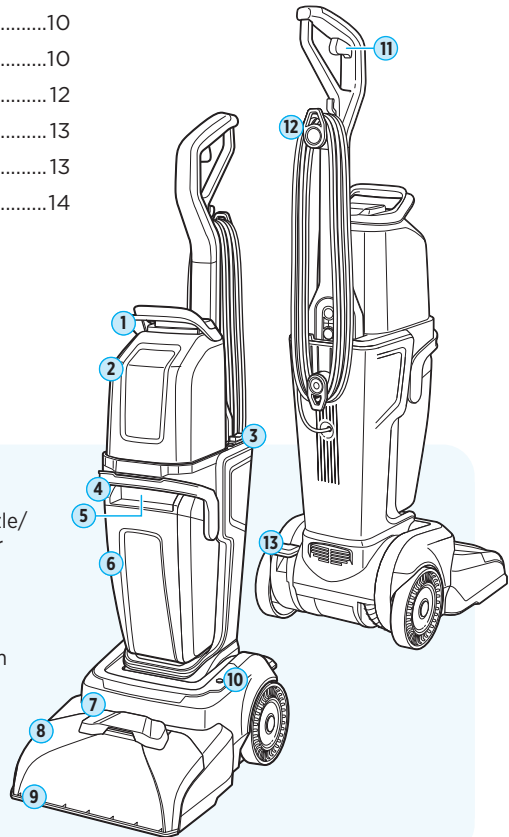





## 4200 SERIES









Important Safety Instructions .....3  
What's in the Box? ..... 4  
Assembly ..... 4  
Cleaning Modes and Stain Cleaning Guide .....5  
Filling the Clean Water Tank..... 6  
Cleaning Modes.....7  
Cleaning with the Hose and Tool..... 9  
Cleaning the Machine  
with Self-Cleaning Tough Stain Tool .....10  
After-Cleaning Care .....10  
Replacing the Belts and Brush Rolls .....12  
Storing Your Machine .....13  
Troubleshooting.....13  
Limited Warranty .....14



### Product Overview

- 1. Clean Water Tank Carry Handle
- 2. Clean Water Tank
- 3. Power Switch
- 4. Dirty Water Tank Carry Handle
- 5. Machine Carry Handle
- 6. Dirty Water Tank
- 7. Accessory Hose Door
- 8. Removable Nozzle/ Brush Roll Cover
- 9. HydroSteam Bar
- 10. Steam Ready Indicator Light
- 11. Solution & Steam Spray Trigger
- 12. Quick Release Cord Wrap
- 13. Recline Pedal

SYMBOL	EXPLANATION
	Caution.
	Read operator's manual.
	Risk of fire.
	Risk of electric shock.
	For indoor use only.
	Do not overwet carpet. Use only on carpet moistened by the cleaning process.
	Use only BISSELL® cleaning formulas intended for use with this machine.
	Disconnect power before servicing.
	Protection against moving parts.
	Risk of automatic start-up.
	WARNING: Danger of scalding. Steam.

SYMBOL	EXPLANATION
	Caution, hot surface.
	This symbol on the product and/or accompanying documents means that used electrical and electronic products should not be mixed with general household waste. For proper treatment, recovery and recycling, please take this product to designated collection points. Please contact your local authority for further details of your nearest designated collection point.
	Do not freeze.
	Motorized cleaning head for water suction cleaning.
	Corrugated Recycles.
	Warning: Slippery surface.
	Fluid.
	Combination of steam and fluid.
	Paper

# IMPORTANT SAFETY INSTRUCTIONS



## READ ALL INSTRUCTIONS BEFORE USING YOUR APPLIANCE.

When using an electrical appliance, basic precautions should be observed, including the following:



## WARNING

### TO REDUCE THE RISK OF FIRE, ELECTRIC SHOCK OR INJURY:

- If the supply cable is damaged, it must be replaced by the manufacturer, its service agent or similarly qualified person in order to avoid a hazard.
- A hazard may occur if the appliance runs over the supply cord.
- The appliance has to be unplugged after use and before carrying out user maintenance on the appliance.
- If appliance is not working as it should, has been dropped, damaged, left outdoors, or dropped into water; do not attempt to operate it and have it repaired at an authorized service center.
- Children should be supervised to ensure that they do not play with the appliance. Cleaning and user maintenance shall not be made by children without supervision.
- Floor slippery when wet.
- Liquid must not be directed toward equipment containing electrical components.
- Use only the type and amount of liquids specified under the operations section of this guide.
- Always connect to a properly earthed electrical socket. Do not modify earthed plug.
- This appliance is not intended for use by persons (including children) with reduced physical, sensory or mental capabilities, or lack of experience and knowledge.
- Do not leave appliance when it is plugged in. Unplug from outlet when not in use and before servicing.
- Use indoors only.
- Do not immerse. Use only on carpet moistened by cleaning process.
- Always install float before any wet pick-up operation.
- Do not use for any purpose other than described in this user guide. Use only manufacturer's recommended attachments.
- Do not pull or carry by cable, use cable as a handle, close door on cable, or pull cable around sharp edges or corners. Do not run appliance over cable. Keep cord away from heated surfaces.
- Do not unplug by pulling on cable. To unplug, grasp the plug, not the cable.
- Do not handle plug or appliance with wet hands.
- Do not put any object into openings. Do not use with any opening blocked; keep openings free of dust, lint, hair, and anything that may reduce air flow.

- Keep hair, loose clothing, fingers, and all parts of body away from openings and moving parts of the appliance and its accessories.
- Turn OFF all controls before plugging or unplugging appliance.
- Use extra care when cleaning on stairs.
- Do not use to pick up flammable or combustible materials (lighter fluid, gasoline, kerosene, etc.) or use in areas where they may be present.
- Do not carry the vacuum cleaner while in use.
- Do not pick up anything that is burning or smoking, such as cigarettes, matches, or hot ashes.
- The appliance has to be unplugged after use and before carrying out user maintenance on the appliance.
- Do not turn your appliance ON until you are familiar with all instructions and operating procedures.
- Keep appliance on a level surface.
- Do not use appliance in an enclosed space filled with vapors given off by oil-based paint, paint thinner, some moth-proofing substances, flammable dust, or other explosive or toxic vapors.
- Do not use to pick up toxic material (chlorine bleach, ammonia, drain cleaner, etc.)
- Do not pick up hard or sharp objects such as glass, nails, screws, coins, etc.
- Plastic film can be dangerous. To avoid danger of suffocation, keep away from children.
- When finished using the product, wrap cord around cord wrap for storage. Store unit indoors in a dry location in an area where the product is not likely to get damaged.
- Any other maintenance or servicing not included in this manual should be performed by an authorized service representative.

## SAVE THESE INSTRUCTIONS

### ORIGINAL INSTRUCTIONS.

FOR OPERATION ON A 220-240 VOLT A.C. 50-60 HZ POWER SUPPLY ONLY.

THIS MODEL IS FOR HOUSEHOLD USE ONLY.

## IMPORTANT INFORMATION

- To reduce the risk of a leaking condition, do not store where freezing may occur.
- Damage to internal components may result.
- Plastic tanks are not dishwasher safe. Do not put tanks in dishwasher.
- Brush roll continues to turn while product is turned on and handle is in use. To avoid damage to carpet, rugs, furniture and flooring, avoid tipping cleaner or setting it on furniture, fringed area rugs, or carpeted stairs during tool use.
- With brush roll on, do not allow cleaner to sit in one location for an extended period of time, as damage to floor can result.

# TOOLS INCLUDED IN BOX WILL DIFFER BY MODEL

To see what's included with your purchase, check the "Carton Contents" list on the top flap of the box.



Lower Body with Dirty Water Tank



Clean Water Tank



Handle



Hose & Tool Bag



Tools  
(vary by model)



Nozzle  
Clean-Out Tool



Trial Cleaning  
Solutions

## Assembly

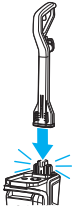

**1.** Insert handle until it clicks into place.

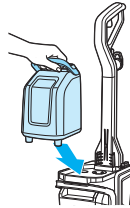

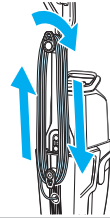

**2.** Insert clean tank until it clicks into place.



**3.** Wrap power cord around cord wraps.

# Cleaning Modes and Stain Cleaning Guide

## A Mode Switch

-  SteamWash Max (II)
-  Steam Pretreat (I)
-  OFF (O)

## B Power Indicator Light

Illuminates when machine is ON, in SteamWash Max and Steam Pretreat modes.

## C Steam Ready Light

In Steam Pretreat and SteamWash Max modes, the steam ready light will illuminate once the machine's steam heater has warmed up, which takes approximately 35 seconds.

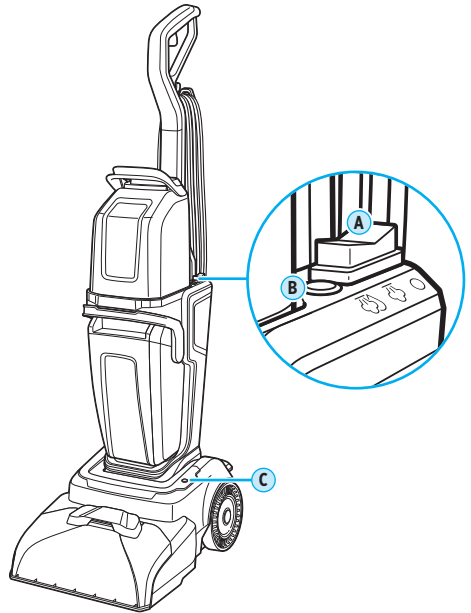

## Stain Cleaning Guide



### Steam Pretreat

For sticky messes

- Slime
- Jelly
- Syrup
- Honey
- Caramel/Chocolate Sauce

*Do not use Steam Pretreat mode on blood or urine*



### SteamWash™ Max

For everyday messes

- Blood
- Urine
- Juice
- Wine
- Mud/Dirt
- Grease
- Vomit
- Baby Food
- Spaghetti Sauce

## Filling the Clean Water Tank



This machine is compatible with BISSELL® formulas made for upright carpet cleaners. For optimal performance, use genuine BISSELL formulas in your machine. Other formulas or household cleaners may cause defects or damage to the machine.

<p><b>1.</b> Choose your formula.* Visit <a href="http://BISSELL.co.uk">BISSELL.co.uk</a> for formulas.</p>	<p><b>2.</b> Lift tank to remove from machine. Flip open lid.</p>	<p><b>3.</b> Choose large or small area fill lines to suit your needs.</p>

<p><b>4.</b> Add <b>warm tap water</b> (60°C max) to water fill line. <b>Do not use boiling water. Do not heat water in microwave.</b> <i>Small Area:</i> 1.8L <i>Large Area:</i> 3.7L</p>	<p><b>5.</b> Add <b>BISSELL formula</b> to formula fill line. <i>Small Area:</i> 73mL <i>Large Area:</i> 145mL</p>	<p><b>6.</b> Close lid until it clicks. Reinstall clean tank.</p>

**\*Compatible formulas include:** Wash & Protect Pro Stain & Odour, Wash & Protect Pet Stain & Odour, Wash & Protect Stain & Odour, Stain Pretreat, Pet Stain Pretreat, Oxy Boost, Natural Carpet Deep Cleaning Solution, Natural Pet Carpet Deep Cleaning Solution

**⚠ WARNING** To reduce the risk of fire and electric shock due to internal component damage, use only BISSELL cleaning formula intended for use with this machine.







## Tips Before Cleaning

- This machine is a carpet cleaner with a steam-cleaning feature, and is not to be used as a dry vacuum.
- For best results, thoroughly dry vacuum your carpet before using this carpet cleaner.
- We recommend checking the care label and/or manufacturer's cleaning instructions for carpets, rugs, upholstery, and car interiors prior to using. Not recommended for use on pure/synthetic wool loop pile, viscose, jute, silk, leather, or natural suede.
- To prevent damage to Berber-style carpets, avoid repeated strokes in the same area. Before cleaning area rugs, check the manufacturer's tag and test an inconspicuous spot on the rug for colorfastness. **Do not use on silk or delicate rugs.**
- Stay off carpet until dry.

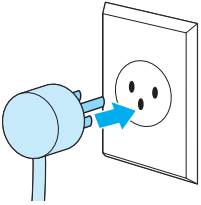
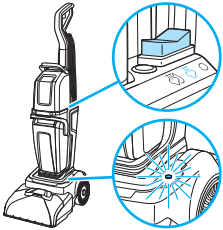
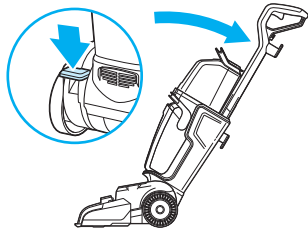

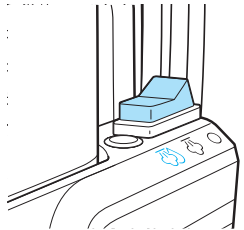
## Steam Pretreat Mode

Use this mode to loosen sticky, stuck-on messes (refer to messes on page 5). **Brush roll and vacuum motor will not turn on in this mode.** Hose cannot be used in this mode. Power indicator light will remain on.

		
<p><b>1.</b> Plug into a properly grounded outlet.</p>	<p><b>2.</b> Press switch to Steam Pretreat  mode (I). The orange steam indicator light on the foot will turn on when the steam heater is ready (about 35 seconds).</p>	<p><b>3.</b> Press recline pedal to recline machine.</p>
		
<p><b>4.</b> Pull trigger to release steam and move machine forward and back over stain for 20 seconds.</p>	<p><b>5.</b> After steam pretreating, press the rocker switch SteamWash™ Max Clean  mode (II) and continue on next page.</p>	<p>CONTINUED ON NEXT PAGE </p>

## SteamWash™ Max Clean Mode

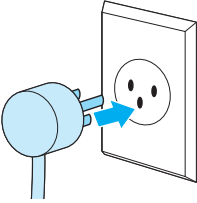
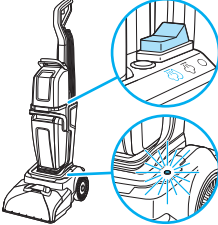
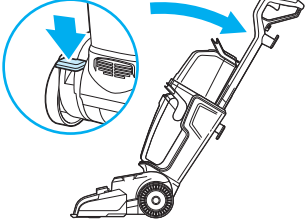
Uses water, formula, and steam to clean your carpet. Carpets will dry in 3-4 hours.

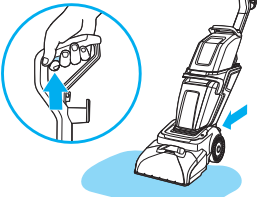
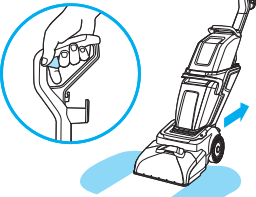
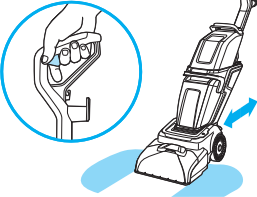
		
<p><b>1.</b> Plug into a properly grounded outlet.</p>	<p><b>2.</b> Press switch to SteamWash™ Max Clean  mode (II). The steam ready indicator light will illuminate when the heater is warmed up and ready for use.</p>	<p><b>3.</b> Press recline pedal to recline machine.</p>
		
<p><b>4.</b> Pull trigger to dispense water, formula, and steam.</p> <p><b>For Heavy Traffic &amp; Routine Cleaning</b></p> <ul style="list-style-type: none"><li>• While holding trigger, make one wet pass moving the machine forward.</li><li>• Release trigger and pull machine backward for one dry pass.</li><li>• Repeat one more wet and dry pass.</li></ul> <p><b>For Stubborn Stains</b></p> <ul style="list-style-type: none"><li>• Trigger may be held in both forward and backward passes until the stain is no longer visible or the water being extracted appears clear.</li></ul>	<p><b>5.</b> For a quicker dry time, release trigger and make “dry passes” by pushing machine forward and back across carpet until water can no longer be seen through the nozzle.</p>	

# Cleaning with the Hose and Tool

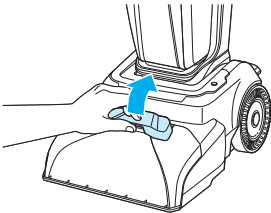
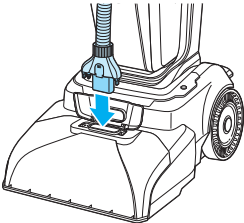
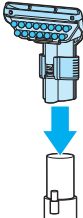
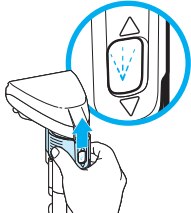
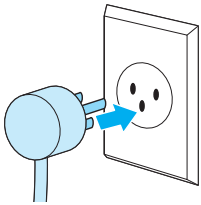
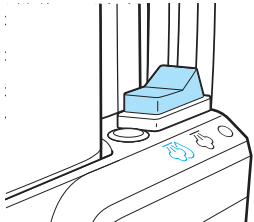
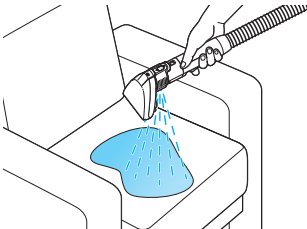
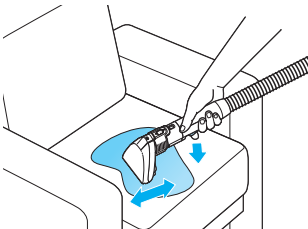
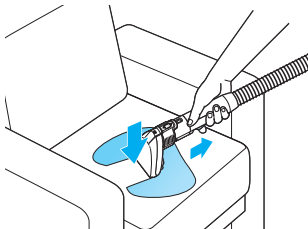

**Note:** Only water and formula flows through hose and tool, not steam.

		
<p><b>1.</b> Lift the accessory hose door on top of foot on the front of the machine. The door flips toward the machine to open.</p>	<p><b>2.</b> Insert the hose until it clicks into place. Be sure the colored hose release clip is facing out, away from machine.</p>	<p><b>3.</b> Attach tool to the end of the hose until it clicks into place.</p>
		
<p><b>4.</b> Slide tool lever up to ensure tool is in SPRAY mode.</p>	<p><b>5.</b> Plug into a proper outlet.</p>	<p><b>6.</b> Press switch all the way forward to SteamWash™ Max Clean mode.</p>
		
<p><b>7.</b> While holding tool above desired area, press and hold trigger to spray solution.</p>	<p><b>8.</b> Release spray trigger and gently scrub stain using bristles.</p>	<p><b>9.</b> With trigger released, press tool firmly against surface and pull towards you to remove stain. Repeat as needed.</p>

## Cleaning the Machine with Self-Cleaning Tough Stain Tool

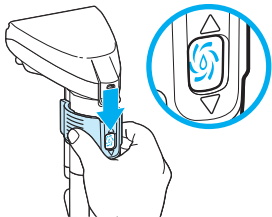
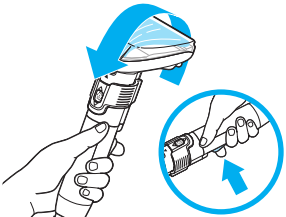
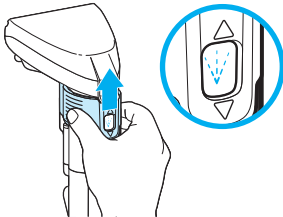

		
<p><b>1.</b> Turn machine ON. Position hand as shown using grip marks on tool. Slide tool lever down for CLEANOUT mode. Ensure there is water and formula in the clean water tank.</p>	<p><b>2.</b> Press trigger to activate CLEANOUT function. Solution will flow through tool and hose.</p> <p><b>Tip:</b> For a more thorough rinse, place suction nozzle on soft surface and tilt forward/backward.</p>	<p><b>3.</b> To continue cleaning with your machine, slide the tool's lever upward to return to SPRAY mode.</p>

## After-Cleaning Care

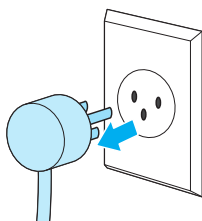
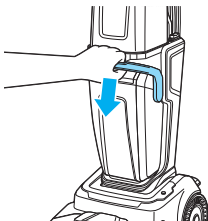
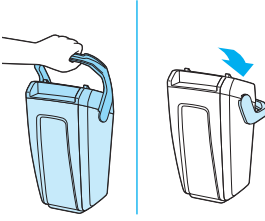

### Emptying the Dirty Water Tank

**Note:** When the tank is full, the float will shut off suction and emit a high-pitched sound indicating it is time to empty your tank. The float engaging from a full dirty water tank will result in a dramatic decrease in suction and must be emptied to continue cleaning.

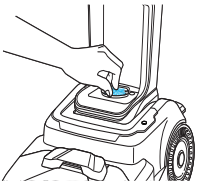
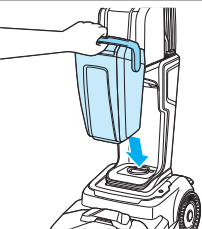
		
<p><b>1.</b> Turn OFF and unplug your machine.</p>	<p><b>2.</b> To release dirty water tank, press down on tank handle and tilt tank toward you.</p>	<p><b>3.</b> Remove tank and carry to disposal area. Unlock by rotating handle back. Grab lid in recessed area on both sides and pull up to remove.</p>
		
<p><b>4.</b> Empty dirty water into utility sink. Reinstall lid and rotate handle forward to lock in place.</p>	<p><b>5.</b> Use a cloth to wipe and remove any debris on the red filter under the dirty water tank.</p>	<p><b>6.</b> Reinstall tank. <b>Insert bottom first.</b> Then, tilt tank toward machine and push top in until it clicks into place.</p>

## Cleaning the Machine

Nozzle may be HOT. Let machine cool before touching.

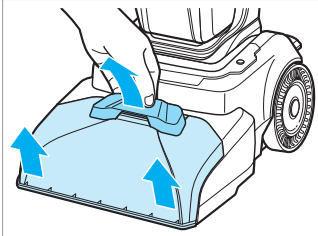

**1.** Pull the nozzle upward and away from the machine.

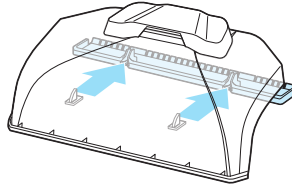

**2.** Pull Catch and Clean tray straight out.

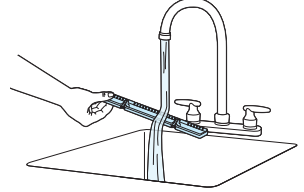

**3.** Empty debris in the garbage, rinse clean and then set aside.

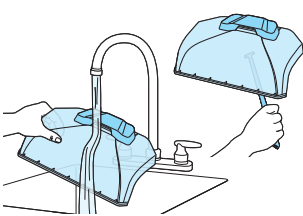

**4.** Open hose door. Rinse nozzle with warm water. Remove debris with clean out tool. **Note:** Parts are not dishwasher or automatic washing machine safe.

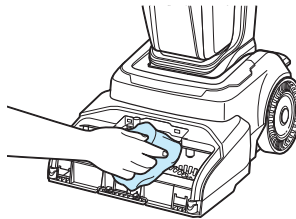

**5.** If brush roll chamber is dirty, clean with a cloth. Then tip the machine back and wipe off the steam bar.

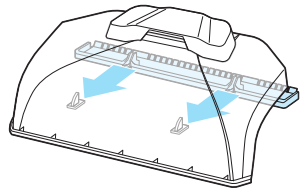

**6.** Insert Catch and Clean Tray into the nozzle by aligning the arrows on the nozzle with the notches on the tray.

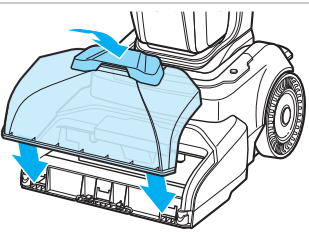

**7.** Let nozzle dry before reassembling. Reinstall nozzle by first lining up tabs with grooves of foot. Rotate nozzle back into place and push near the graphics until you feel two clicks.

**⚠ WARNING** To reduce the risk of injury, do not touch the steam cleaning nozzle or adjacent surfaces when steam-cleaning or when the nozzle is heated.

# Replacing the Belts and Brush Rolls

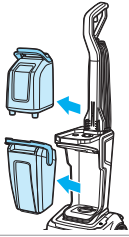

**1.** Turn OFF and unplug machine. Remove both tanks. While reclined, lay machine on its front.

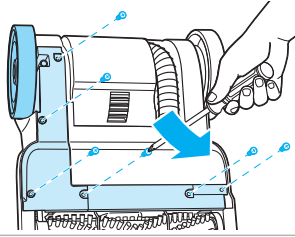

**2.** Use Phillips-head screwdriver to remove six screws.

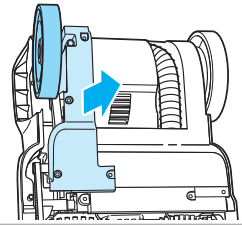

**3.** Remove belt access cover.

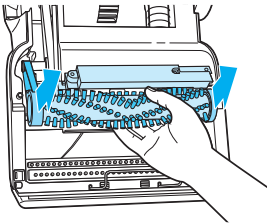

**4.** Pull brush roll assembly upward. Remove cogged belt from motor shaft to remove assembly from machine. If either brush roll belt or assembly are broke, order a brush roll assembly.

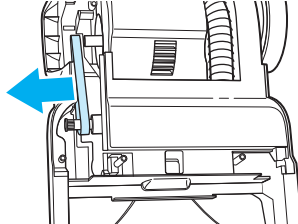

**5.** Remove flat belt from motor shaft and red pulley. If belt is broken or badly worn, replace with a new flat belt. Install flat belt by placing it around red pulley and stretching it back around motor shaft. Rotate belt by hand to center on pulley.

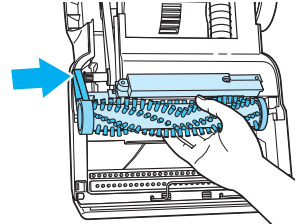

**6.** Place cogged belt around cogged motor shaft and install brush roll assembly into machine.

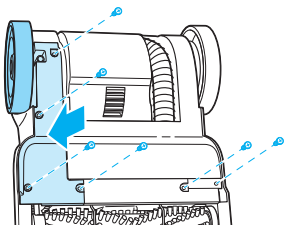

**7.** Install belt access cover. Use a Phillips-head screwdriver to secure cover and assembly in place with six screws.

**⚠ WARNING** To reduce the risk of injury, do not touch the steam cleaning nozzle or adjacent surfaces when steam-cleaning or when the nozzle is heated.

## Storing Your Machine

When finished using the product, wrap cord around cord wrap for storage. Store unit indoors in a dry location in an area where the product is not likely to get damaged.

Any other maintenance or servicing not included in this manual should be performed by an authorized service representative. Any other servicing should be performed by an authorized service representative.

## Troubleshooting

 Below are some of the issues you may run into. If you don't see the issue you're experiencing below, visit [support.BISSELL.co.uk](http://support.BISSELL.co.uk).

Problem	Possible Cause	Remedies
Reduced spray OR no spray	Clean water tank may be empty.	Refill tank.
	Clean water tank may not be seated completely.	Turn power off. Remove and reseal tank.
No spray through hose & tool	The hose to machine is not primed.	Turn off and unplug the machine. Remove nozzle from foot. Insert pen in black cylinder next to screw. Wait for water bubbles, remove pen. Reassemble nozzle and hose.
	Pump may have lost prime in hose cleaning mode.	Turn unit on. Hold end of the hose close to the ground and press the hose trigger until the system is primed.
Loss of suction	Dirty water tank may not be seated properly.	Reseat dirty water tank so it fits properly.
	Dirty water tank is full.	Empty dirty water tank.
	Rubber tab on dirty water tank is not sealed tight.	Check rubber tab on dirty water tank and press firmly on all edges to secure tightly.
	Nozzle not installed correctly.	Remove and reinstall nozzle.
No power	Outlet may not be active.	Try plugging in a different device that uses a grounded outlet to test for power from outlet.
No steam	Steam not ready.	Ensure steam indicator LED has turned on.

# Limited Warranty

This limited warranty is provided by BISSELL® International Trading Company B.V. ("BISSELL") and applies in Australia and New Zealand. It gives you specific rights. It is offered as an additional benefit to your rights under law. You also have other rights under The Australian Consumer Law or New Zealand Consumer Laws, whichever applies to you. You can find out about your legal rights and remedies by contacting your local consumer advice service. Nothing in this warranty will replace or lessen any of your legal rights or remedies. If you need additional instruction regarding this warranty or have questions regarding what it may cover, please contact BISSELL Consumer Care or contact your local distributor.

This warranty is given to the current owner of the product with the original sales receipt. The original sales receipt must include the product(s) purchased, the date purchased, and which country it was purchased from new. You must be able to evidence the date of purchase and show the product was purchased in Australia or New Zealand to submit a claim under this warranty. You will receive the warranty that is applicable to the country where your product was originally purchased, as shown on the original sales receipt. If you use the product outside of the country where it was purchased, your warranty may be void in BISSELL's sole discretion. It may be necessary to obtain some of your personal information, such as a mailing address, to fulfill the terms of this warranty. Any personal data will be handled pursuant to BISSELL's Privacy Policy, which can be found at [global.BISSELL.com/privacy-policy](http://global.BISSELL.com/privacy-policy).

## Limited 2- or 3-Year Warranty (varies by model)

**Model 4200F:** Limited 2-Year Warranty

**Model 4200H:** Limited 3-Year Warranty

For the specified duration above from the date of purchase by the original purchaser, subject to the \*EXCEPTIONS AND EXCLUSIONS identified below, BISSELL will repair or replace (with new, refurbished, lightly used, or remanufactured components or products), at BISSELL's option, free of charge, any defective or malfunctioning part or product.

BISSELL recommends that the original packaging and original proof of purchase with the date of purchase and country where purchased be kept for the duration of the warranty period in case you want to redeem the warranty during the warranty period. Keeping the original packaging will assist with any necessary re-packaging and transportation but is not a condition of the warranty.

If your product is replaced by BISSELL under this warranty, then the new item will benefit from the remainder of the term of this warranty (calculated from the date of the original purchase). The period of this warranty shall not be extended whether or not your product is repaired or replaced.

## \*Conditions of Warranty

This warranty applies to products used for personal domestic use and not commercial or hire purposes. Consumable components and attachments such as filters, belts, shells, water tanks, scraping strips, brushes, and mop pads, which must be replaced or serviced by the user from time to time, are not covered by this warranty.

This warranty does not apply to any defect arising from fair wear and tear, including but not limited to the battery discharging time shortening due to the aging or use. Damage or malfunction caused by the user or any third party whether as a result of accident, negligence, abuse, neglect, or any other use not in accordance with the user guide is not covered by this warranty. An unauthorised repair (or attempted repair) may void this warranty whether or not damage has been caused by that repair/attempt. Removing or tampering with the Product Rating Label on the product or rendering it illegible will void this warranty.

Except as set out below, BISSELL and its distributors are not liable for any loss or damage that is not foreseeable or for incidental or consequential damages of any nature associated with the use of this product including without limitation loss of profit, loss of business, business interruption, loss of opportunity, distress, inconvenience, or disappointment. Except as set out below, BISSELL's liability will not exceed the purchase price of the product.

BISSELL does not exclude or limit in any way its liability for (a) death or personal injury caused by our negligence or the negligence of our employees, agents or subcontractors; (b) fraud or fraudulent misrepresentation; (c) or for any other matter which cannot be excluded or limited under law.

To make a claim under this warranty contact BISSELL Australia PTY LTD (details below). Contact BISSELL prior to returning any goods. Where agreed, BISSELL will reimburse reasonable postage / handling costs (if any) for returning goods to BISSELL. To claim expenses incurred in making a claim under this warranty please provide BISSELL with a copy of the receipt of the expenses by email or post.

For Australian Consumers Only: Our goods come with guarantees that cannot be excluded under the Australian Consumer Law. You are entitled to a replacement or refund for a major failure and compensation for any other reasonably foreseeable loss or damage. You are also entitled to have the goods repaired or replaced if the goods fail to be of acceptable quality and the failure does not amount to a major failure.

## Important Notes

- Please keep your original sales receipt. It provides proof of the date of purchase and where it was purchased in the event of a warranty claim. See warranty for details.
- Please note that using your BISSELL machine outside of its country of original purchase and/or use with a power converter may damage your BISSELL machine and damage caused by mismatched power voltage will not be covered by your warranty.
- Please note that putting vinegar, bleach, dish soap, detergent, homemade soap, and other non-BISSELL products in your BISSELL machine may damage your BISSELL machine. Damage caused by using non-BISSELL products in your machine will not be covered by your warranty.

## Consumer Care

If your BISSELL product should require service or to claim under our limited guarantee, please contact us.



### Australia

Telephone: 1300 247 735  
Website: [BISSELL.com.au](http://BISSELL.com.au)  
Address: 789 Springvale Road,  
Mulgrave, Victoria 3170  
Email: [consumercareau@bissell.com](mailto:consumercareau@bissell.com)



### New Zealand

Telephone: 0800 247 735  
Website: [BISSELL.co.nz](http://BISSELL.co.nz)  
Address: 789 Springvale Road,  
Mulgrave, Victoria 3170  
Email: [consumercarenz@bissell.com](mailto:consumercarenz@bissell.com)

## Need more support?

Head to <https://bissell.com.au/pages/contact> to troubleshoot, register your product, view your warranty, and more.



INFO



REGISTER



VIDEOS



PARTS



SUPPORT



PAP



©2026 BISSELL Inc. All rights reserved.  
Part Number 1647043 01/26 v3