



SPOTCLEAN™ PROHEAT™

PORTABLE CARPET & UPHOLSTERY CLEANER

MODELS 3924F, 3924H





Carton Contents.....	3	Using the Tools.....	6
Assembly.....	3	Emptying the Dirty Water Tank.....	8
Filling the SmartMix™ Tank.....	4	Cleaning and Storing Your Machine.....	9
Getting Ready to Clean.....	5	Limited Warranty.....	10



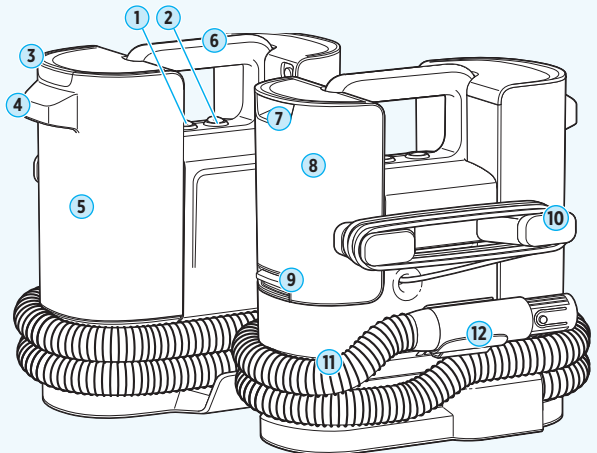







Product Overview

- 1. Power Switch
- 2. ProHeat Mode Switch
- 3. Dirty Tank Lid
- 4. Dirty Tank Handle
- 5. Dirty Tank (Float Stack inside)
- 6. Carry Handle
- 7. SmartMix Handle
- 8. SmartMix Tank
- 9. Cleaning Mode Switch
- 10. Power Cord Wrap
- 11. Hose
- 12. Hose Clip



SYMBOL	EXPLANATION
	Caution.
	Read operator's manual.
	Risk of fire.
	Risk of electric shock.
	Do not expose to rain.
	Store indoors.
	Do not overwet carpet. Use only on carpet moistened by the cleaning process.
	Use only BISSELL® cleaning formulas intended for use with this machine.
	Disconnect power before servicing.

SYMBOL	EXPLANATION
	This symbol on the product and/or accompanying documents means that used electrical and electronic products should not be mixed with general household waste. For proper treatment, recovery and recycling, please take this product to designated collection points. Please contact your local authority for further details of your nearest designated collection point.
	Do not freeze.
	Warning: Slippery surface.
	Heat fluid.
	Elapsed time, wait 30 seconds to heat fluid.
	Allow parts to dry.
	Use warm water, temperature up to 60°C.
	Check the manufacturer's tag before cleaning textile. "W" on the tag as shown means you can use your cleaner.

IMPORTANT SAFETY INSTRUCTIONS

READ ALL INSTRUCTIONS BEFORE USING YOUR APPLIANCE.

When using an electrical appliance, basic precautions should be observed, including the following:



WARNING TO REDUCE THE RISK OF FIRE, ELECTRIC SHOCK OR INJURY:

- This appliance can be used by persons with reduced physical, sensory or mental capabilities or lack of experience and knowledge if they have been given supervision or instruction concerning use of the appliance in a safe way and understand the hazards involved. Children shall not play with the appliance.
- This appliance is not intended for use by persons with reduced physical, sensory or mental capabilities, or lack of experience and knowledge, unless they have been given supervision or instruction concerning use of the appliance by a person responsible for their safety.
- Children should be supervised to ensure that they do not play with the appliance.
- Keep hair, loose clothing, fingers, and all parts of body away from openings and moving parts of the appliance and its accessories.
- The appliance has to be unplugged after use and before carrying out user maintenance on the appliance.
- If the supply cable is damaged, it must be replaced by the manufacturer, its service agent or similarly qualified person in order to avoid a hazard.
- Do not leave appliance when it is plugged in. Unplug from outlet when not in use and before servicing.
- Do not pull or carry by cable, use cable as a handle, close door on cable, or pull cable around sharp edges or corners. Do not run appliance over cable. Keep cord away from heated surfaces.
- Do not unplug by pulling on cable. To unplug, grasp the plug, not the cable.
- Do not handle plug or appliance with wet hands.

- Turn OFF all controls before plugging or unplugging appliance.
- Plastic film can be dangerous. To avoid danger of suffocation, keep away from children.
- Do not use for any purpose other than described in this user guide. Use only manufacturer's recommended attachments.
- If appliance is not working as it should, has been dropped, damaged, left outdoors, or dropped into water; do not attempt to operate it and have it repaired at an authorized service center.
- Do not put any object into openings. Do not use with any opening blocked; keep openings free of dust, lint, hair, and anything that may reduce air flow.
- Use extra care when cleaning on stairs.
- Do not use to pick up flammable or combustible materials (lighter fluid, gasoline, kerosene, etc.) or use in areas where they may be present.
- Do not pick up toxic material (chlorine bleach, ammonia, drain cleaner, etc.)
- Do not use appliance in an enclosed space filled with vapours given off by oil-based paint, paint thinner, some moth-proofing substances, flammable dust, or other explosive or toxic vapors.
- Keep appliance on a level surface.
- Do not pick up anything that is burning or smoking, such as cigarettes, matches, or hot ashes.
- Do not expose to rain. Store indoors.
- Always connect to a properly earthed electrical socket. Do not modify earthed plug.
- Liquid must not be directed toward equipment containing electrical components.

- Use only the type and amount of liquids specified under the operations section of this guide.
- Always install float before any wet pick-up operation.

- Do not turn your appliance ON until you are familiar with all instructions and operating procedures.
- Floor slippery when wet.

SAVE THESE INSTRUCTIONS

ORIGINAL INSTRUCTIONS. FOR OPERATION ON A 220-240 VOLT A.C. 50-60 HZ POWER SUPPLY ONLY. THIS MODEL IS FOR HOUSEHOLD USE ONLY.

IMPORTANT INFORMATION

To reduce the risk of a leaking condition, do not store where freezing may occur. Damage to internal components may result.

TOOLS INCLUDED IN BOX WILL DIFFER BY MODEL

To see what's included with your purchase, check the "Carton Contents" list on the top flap of the box.

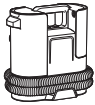

Machine



2-in-1 Tough Stain Tool
(select models)

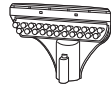

15cm Tool
(select models)



Spraying Crevice Tool
(varies by model)



DeepStain Tool
(select models)



Trial Formula(s)
(vary by model)

Assembly

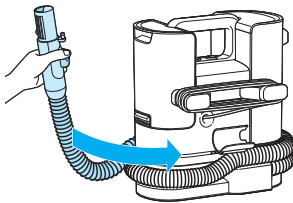

1. Wrap hose around bottom of machine.

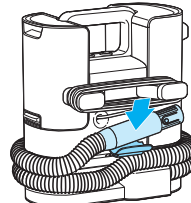

2. Secure hose on hose clip.

Filling the SmartMix™ Tank



For optimal performance, use genuine BISSELL® formulas in your machine. Other formulas or household cleaners may cause defects or damage to the machine.



1. Choose your formula.*
Scan the QR code with your smartphone camera or visit global.BISSELL.com for formulas.

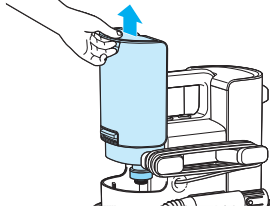

2. Remove SmartMix tank by gripping tank handle and lift up.

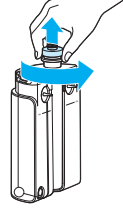

3. Unscrew cap on the water side of the SmartMix tank.

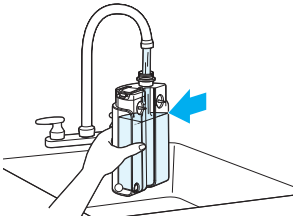

4. Fill with warm (60°C MAX) tap water to water fill line. Do not use boiling water. Do not heat water in microwave.

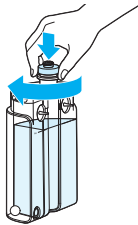

5. Align cap with tank and fully insert. Securely screw cap onto machine.

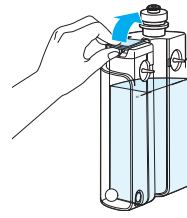

6. Open the cover on the formula side of the SmartMix tank.

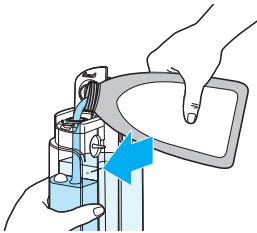

7. Slowly pour in formula. Add cleaning formula* to formula fill line. **Note: There is a formula level indicator ball to help visually indicate how much formula you have left.**



8. Close formula cover until it clicks. Align tank with machine and press down until it clicks into place.

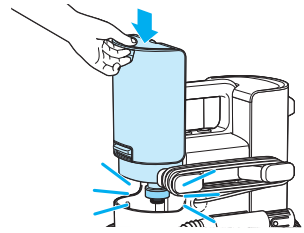

***Compatible BISSELL formulas include:** Pet Stain and Odour, Spot and Stain, Oxy Boost.

⚠ WARNING

- To reduce the risk of fire and electric shock due to internal component damage, use only BISSELL cleaning formula intended for use with this machine.
- Do not plug in your cleaner until you are familiar with all instructions and operating procedures.

Using Your Machine



- Vacuum to remove loose dirt from areas to be cleaned.
- Spray any BISSELL stain pretreat formula on soiled areas and allow to sit for a few minutes.
- **Tip:** For upholstery, work in small sections until area is clean.

<p>1. Unwrap hose</p>	<p>2. Attach your desired tool to end of hose until it clicks into place.</p>	<p>3. Unwrap power cord and plug into a grounded outlet.</p>

<p>4. Choose desired cleaning method.</p> <p>Deep Clean Mode: Automatically mixes the correct ratio of formula and water to clean tough stains</p> <p>Rinse Mode: Provides option for a water only clean</p>	<p>5. To turn machine on, flip power switch to the ON (I) position.</p>

6. Optional: Press ProHeat switch () to activate heater. Wait 30 seconds for water to heat to temperature. ProHeat Technology provides better, faster cleaning to loosen and remove tough stains, like oily messes and old set-in stains.

Using the Tools

Tools included in box will differ by model. Check the the top flap of the box to see what's included with your purchase.



Spraying Crevice Tool (select models)

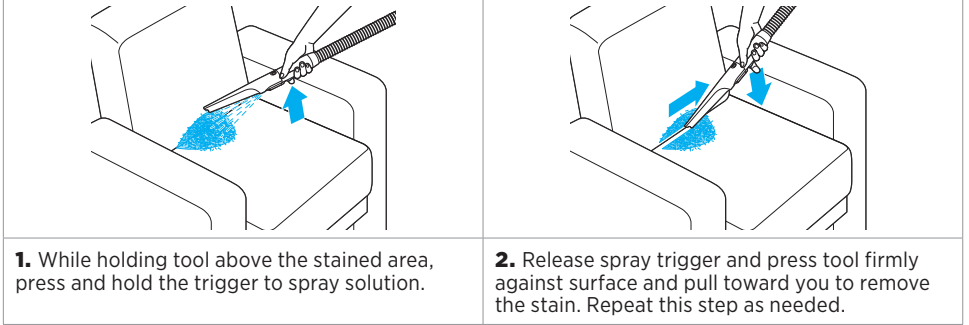

2-in-1 Tough Stain Tool (select models)

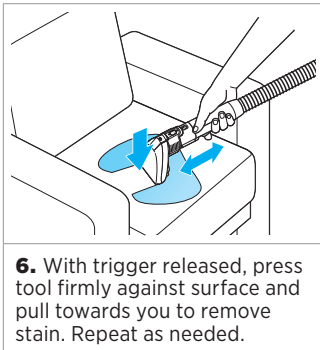
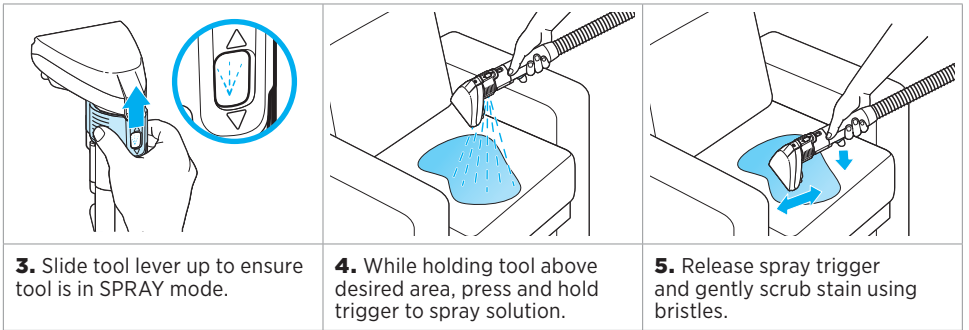

15cm Tool

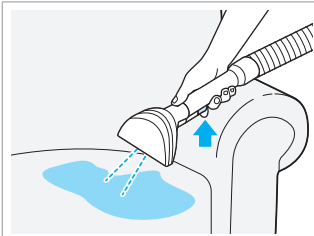

1. Point the tool above the desired area, press and hold the trigger to spray the solution

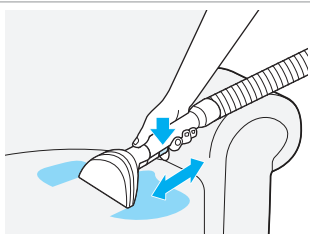

2. Release the trigger and gently scrub with bristles. Press firmly against the surface and pull towards you to remove the stain. Repeat as needed.

Deep Stain Tool

Note: Always keep tool in contact with carpet to avoid over-spraying.

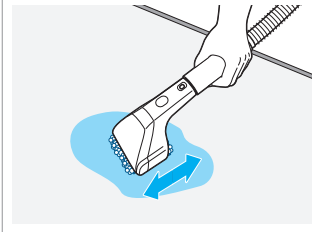

1. Set the tool directly on to the carpet. Press and hold trigger to spray solution.

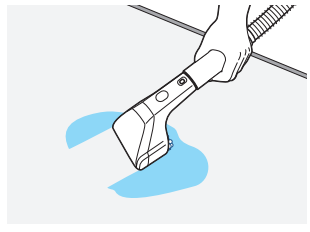

2. Scrub back and forth to suction away the spot or stain. After releasing the trigger make additional passes to remove excess solution.

Emptying the Dirty Water Tank

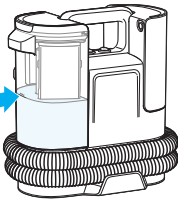

1. Empty dirty water tank when “MAX” full line is reached. **Do not allow water level to exceed MAX full line.**

Note: The machines pitch will change and suction will stop once the MAX fill line has been reached.

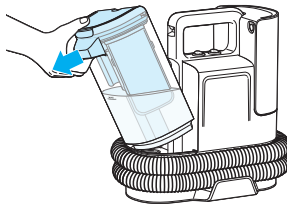

2. Tilt and pull away dirty water tank to remove from machine.

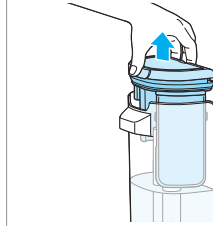

3. Pull up on dirty tank lid to remove.

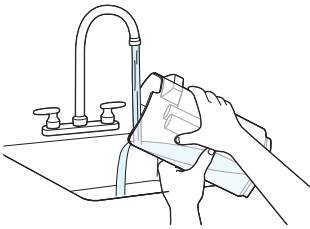

4. Pour out dirty water and rinse tank.

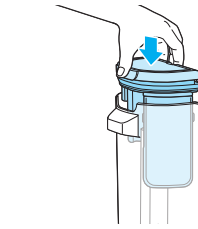

5. Reinstall tank lid.

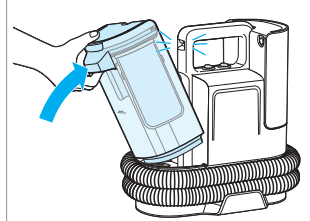

6. To reinstall tank, tilt and push firmly near top of tank until it clicks into place

Cleaning and Storing Your Machine

Cleaning the Machine with the 2-in-1 Tough Stain Tool (select models)

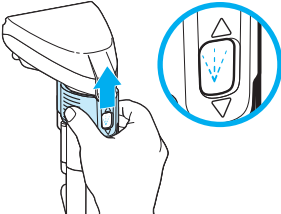
		
<p>1. Turn machine ON. Slide tool lever down for cleanout mode.</p>	<p>2. Press the trigger to activate the CLEANOUT function. Solution mixture will come through the tool and the hose.</p>	<p>3. To continue cleaning with your machine, slide the tool's lever upward to return to spray mode.</p>

Storing Your Machine

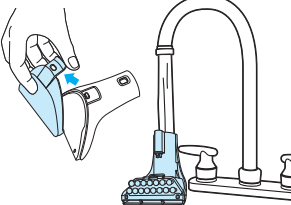
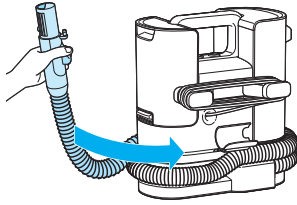
	
<p>1. Remove and rinse tools under clean, running water. Allow tools to dry.</p>	<p>2. Wrap hose for storage. Store indoors in a secure, dry location.</p>

Note: Other maintenance or service not included in this manual should be performed by an authorised service representative.

NOTICE: To reduce the risk of a leaking condition, do not store where freezing may occur. Damage to internal components may result. Store machine in protected, dry area at room temperature (4°C - 40°C).

⚠ WARNING To reduce the risk of fire and electric shock due to internal component damage, use only BISSELL cleaning formula intended for use with this machine.

Limited Warranty

This limited warranty is provided by BISSELL® International Trading Company B.V. ("BISSELL") and applies in Australia and New Zealand. It gives you specific rights. It is offered as an additional benefit to your rights under law. You also have other rights under The Australian Consumer Law or New Zealand Consumer Laws, whichever applies to you. You can find out about your legal rights and remedies by contacting your local consumer advice service. Nothing in this warranty will replace or lessen any of your legal rights or remedies. If you need additional instruction regarding this warranty or have questions regarding what it may cover, please contact BISSELL Consumer Care or contact your local distributor.

This warranty is given to the current owner of the product with the original sales receipt. The original sales receipt must include the product(s) purchased, the date purchased, and which country it was purchased from new. You must be able to evidence the date of purchase and show the product was purchased in Australia or New Zealand to submit a claim under this warranty. You will receive the warranty that is applicable to the country where your product was originally purchased, as shown on the original sales receipt. If you use the product outside of the country where it was purchased, your warranty may be void in BISSELL's sole discretion. It may be necessary to obtain some of your personal information, such as a mailing address, to fulfill the terms of this warranty. Any personal data will be handled pursuant to BISSELL's Privacy Policy, which can be found at global.BISSELL.com/privacy-policy.

Limited 2- or 3-Year Warranty (varies by model)

Model 3924F: Limited 2-Year Warranty

Model 3924H: Limited 3-Year Warranty

For two or three years from the date of purchase by the original purchaser, subject to the *EXCEPTIONS AND EXCLUSIONS identified below, BISSELL will repair or replace (with new, refurbished, lightly used, or remanufactured components or products), at BISSELL's option, free of charge, any defective or malfunctioning part or product.

BISSELL recommends that the original packaging and original proof of purchase with the date of purchase and country where purchased be kept for the duration of the warranty period in case you want to redeem the warranty during the warranty period. Keeping the original packaging will assist with any necessary re-packaging and transportation but is not a condition of the warranty.

If your product is replaced by BISSELL under this warranty, then the new item will benefit from the remainder of the term of this warranty (calculated from the date of the original purchase). The period of this warranty shall not be extended whether or not your product is repaired or replaced.

*Conditions of Warranty

This warranty applies to products used for personal domestic use and not commercial or hire purposes. Consumable components and attachments such as filters, belts, shells, water tanks, scraping strips, brushes, and mop pads, which must be replaced or serviced by the user from time to time, are not covered by this warranty.

This warranty does not apply to any defect arising from fair wear and tear, including but not limited to the battery discharging time shortening due to the aging or use. Damage or malfunction caused by the user or any third party whether as a result of accident, negligence, abuse, neglect, or any other use not in accordance with the user guide is not covered by this warranty. An unauthorised repair (or attempted repair) may void this warranty whether or not damage has been caused by that repair/attempt. Removing or tampering with the Product Rating Label on the product or rendering it illegible will void this warranty.

Except as set out below, BISSELL and its distributors are not liable for any loss or damage that is not foreseeable or for incidental or consequential damages of any nature associated with the use of this product including without limitation loss of profit, loss of business, business interruption, loss of opportunity, distress, inconvenience, or disappointment. Except as set out below, BISSELL's liability will not exceed the purchase price of the product.

BISSELL does not exclude or limit in any way its liability for (a) death or personal injury caused by our negligence or the negligence of our employees, agents or subcontractors; (b) fraud or fraudulent misrepresentation; (c) or for any other matter which cannot be excluded or limited under law.

To make a claim under this warranty contact BISSELL Australia PTY LTD (details below). Contact BISSELL prior to returning any goods. Where agreed, BISSELL will reimburse reasonable postage / handling costs (if any) for returning goods to BISSELL. To claim expenses incurred in making a claim under this warranty please provide BISSELL with a copy of the receipt of the expenses by email or post.

For Australian Consumers Only: Our goods come with guarantees that cannot be excluded under the Australian Consumer Law. You are entitled to a replacement or refund for a major failure and compensation for any other reasonably foreseeable loss or damage. You are also entitled to have the goods repaired or replaced if the goods fail to be of acceptable quality and the failure does not amount to a major failure.

Important Notes

Please keep your original sales receipt. It provides proof of the date of purchase and where it was purchased in the event of a warranty claim. See warranty for details.

Please note that using your BISSELL machine outside of its country of original purchase and/or use with a power converter may damage your BISSELL machine and damage caused by mismatched power voltage will not be covered by your warranty.

Please note that putting vinegar, bleach, dish soap, detergent, homemade soap, and other non-BISSELL products in your BISSELL machine may damage your BISSELL machine. Damage caused by using non-BISSELL products in your machine will not be covered by your warranty.

Consumer Care

If your BISSELL product should require service or to claim under our limited guarantee, please contact us.



Australia

Telephone: 1300 247 735

Website: BISSELL.com.au

Address: 789 Springvale Road,

Mulgrave, Victoria 3170

Email: consumercareau@bissell.com



New Zealand

Telephone: 0800 247 735

Website: BISSELL.co.nz

Address: 789 Springvale Road,

Mulgrave, Victoria 3170

Email: consumercarenz@bissell.com

Need more support?

Head to global.BISSELL.com to troubleshoot, order spare parts, view your warranty, and more.



INFO



VIDEOS



PARTS

